

**Trommel Range | Complete Crushing, Screening, Washing & Recycling Solutions**

# Trommel Range





# TEREX | FINLAY



Finlay Hydrascreens (Omagh) Ltd, the pioneers of mobile screening, are world leaders in the manufacturing of Crushing, Screening, Washing and Recycling equipment for use in the Construction, Quarrying, Mining and Aggregate industries.

Based at the modern 400,000 sq. ft. manufacturing base in Omagh, N.Ireland, the factory is equipped with the latest in CNC, PLM, Bar-coding and Sage ERP software technology while all machines are designed with Pro-Engineer wildfire – a 3-D solid modelling package.

Finlay Hydrascreens are renowned for their innovation, quality, service and value for money and have been exporting for over 45 years. Our extensive dealer network can be found on our website [www.finlayhydrascreens.com](http://www.finlayhydrascreens.com)



Finlay Hydrascreens (Omagh) Ltd., pionnier des installations de criblage mobiles, est leader mondial dans la fabrication des matériels de concassage, criblage, lave et recyclage pour les industries des travaux publics, les mines et carrières.

Le siège de la société est basé à Omagh, en Irlande du Nord, a une superficie de 40 000 m<sup>2</sup>. L'usine dispose de machines de pointe pour la production (commande numérique, contrôle par impulsion) ainsi que des équipements modernes de gestion (ERP, code barre).

Tous les machines sont conçues à l'aide du logiciel de CAO 3-D Pro-Engineer

Finlay Hydrascreens est reconnu pour son esprit novateur, sa qualité, son service et pour son bon rapport qualité-prix. Finlay Hydrascreens exporte depuis plus de 45 ans. Vous trouverez son important réseau de points de vente sur notre site internet [www.Finlayhydrascreens.com](http://www.Finlayhydrascreens.com).



Finlay Hydrascreens (Omagh) Ltd, Pioniere im Bereich mobiler Siebanlagen, sind führender Hersteller auf dem Weltmarkt für Brech-, Sieb-, Wasch- und Recyclinganlagen für die Bau-, Bergbau-, Steinbruch- und Gesteinsindustrie.

Der 40000 m<sup>2</sup> große Sitz der Firma ist Omagh, N.Ireland. Das Werk verfügt über neuste Produktionsmaschinen (CNC) und Ausrüstung (PLM, ERP). Alle Produkte werden mit der 3D-CAD-Software Pro-Engineer entwickelt.

Finlay Hydrascreens ist bekannt für Innovation, Qualität, Service und ein gutes Preis-Leistungs-Verhältnis. Finlay Hydrascreens exportiert seit über 45 Jahren. Das umfangreiche Händlernetz finden Sie auf unserer website [www.finlayhydrascreens.com](http://www.finlayhydrascreens.com)



Finlay Hydrascreens (Omagh) Ltd., empresa innovadora en el campo de instalaciones móviles de cribado, es un líder mundial en la fabricación de equipos de trituración, clasificación, lavado y reciclaje para las industrias de construcción, cantera, minas y áridos.

Ubicada en unas instalaciones modernas de 40.000 m<sup>2</sup> en Omagh, Irlanda del Norte, la fábrica está equipada con lo último en tecnología, incluyendo los programas CNC, PLM Y ERP, además de que todas las máquinas están diseñadas con la ayuda del software 3D-CAD Pro-Engineer.

Finlay Hydrascreens es famosa por su capacidad innovadora, calidad, servicio y relación calidad/precio, por ello llevan 45 años exportando sus productos a todas partes del mundo.

Pueden encontrar nuestra extensa red de distribuidores en la página web: [www.finlayhydrascreens.com](http://www.finlayhydrascreens.com)



Finlay Hydrascreens (Omagh) Ltd, azienda pioniera nel settore degli impianti di vagliatura mobili, è uno dei più importanti costruttori a livello mondiale di impianti di frantumazione, di vagliatura, di lavaggio per l'industria edilizia, estrattiva, degli scavi e movimento terra, e del riciclaggio.

La ditta, che ha sede in Omagh, nell'Irlanda del Nord, dispone di un moderno stabilimento equipaggiato, su un'area di 40.000 m<sup>2</sup>, con i più aggiornati macchinari di produzione (CNC) e attrezzature (PLM, ERP). Tutti i prodotti vengono sviluppati con l'ausilio del software 3D-CAD Pro-Engineer.

Finlay Hydrascreens è sinonimo di innovazione, qualità, assistenza e rapporto qualità-prezzo. Finlay Hydrascreens esporta i suoi prodotti da oltre 45 anni.

Per conoscere la nostra rete completa di rivenditori, consultare il nostro sito Internet [www.finlayhydrascreens.com](http://www.finlayhydrascreens.com)

# FINLAY TROMMEL 760



Single Skin direct feed Trommel ideally suited to compost and topsoil applications. Standard features include changeable barrel, hydraulic folding conveyors and pindle hook for transportation. Remote tipping grid or vibrating grid optional.



Trommel à simple virole pour alimentation directe idéal pour le traitement de compost et de terres végétales. L'équipement standard inclut une virole interchangeable, des tapis de stockage à rabattage hydraulique ainsi qu'un crochet d'attelage pour le transport. Un barreudage relevable télécommandé ou un double scalpeur vibrant sont disponibles en option.



Einfach-Trommel zur Direktaufgabe ideal geeignet für Kompost und Mutterboden. Zur Standardausrüstung gehören auswechselbare Siebtrommel, hydraulisch klappbare Förderbänder sowie eine Augenkupplung für den Transport. Ein ferngesteuerter Rost oder ein Vibrationsrost sind auf Wunsch als Extra erhältlich.



El trómel 760, compuesto por una virola, es la máquina idónea para aplicaciones de compostaje y tierra vegetal. Entre sus características más importantes destacan una virola intercambiable, cintas transportadoras que se pliegan hidráulicamente y un enganche robusto para el transporte. Opcionalmente, existe la posibilidad de instalar una rejilla auto-limpiante o parrilla vibrante encima de la tolva.



Tamburo semplice per l'alimentazione diretta ideale per composte e terreno vegetale. La dotazione standard comprende il vaglio a tamburo intercambiabile, nastri trasportatori a ribaltamento idraulico e gancho per il trasporto. Su richiesta, sono anche disponibili separatamente una griglia telecomandata o una griglia vibrante.



## Trommel 760 Technical Specifications

Hopper Capacity:	4cu. metres (5.23cu. yards)
Screen Size:	Length – 4700mm (15' 5") Diameter – 1800mm (5' 11")
Engine:	Yanmar 47kw 4TNV 98 Water Cooled
Belt Feeder:	1050mm (42") Variable Speed Plain Belt
Fines Conveyor:	600mm (24") Variable Speed Chevron Belt
Fines Transfer Conveyor:	1200mm (48") Variable Speed Plain Belt
Oversize Conveyor:	1000mm (39") Variable Speed Chevron Belt
Machine Weight:	Tracked 17.5 Tonnes (19.3 US Tons) Wheeled model 15 Tonnes (16.5 US Tons)



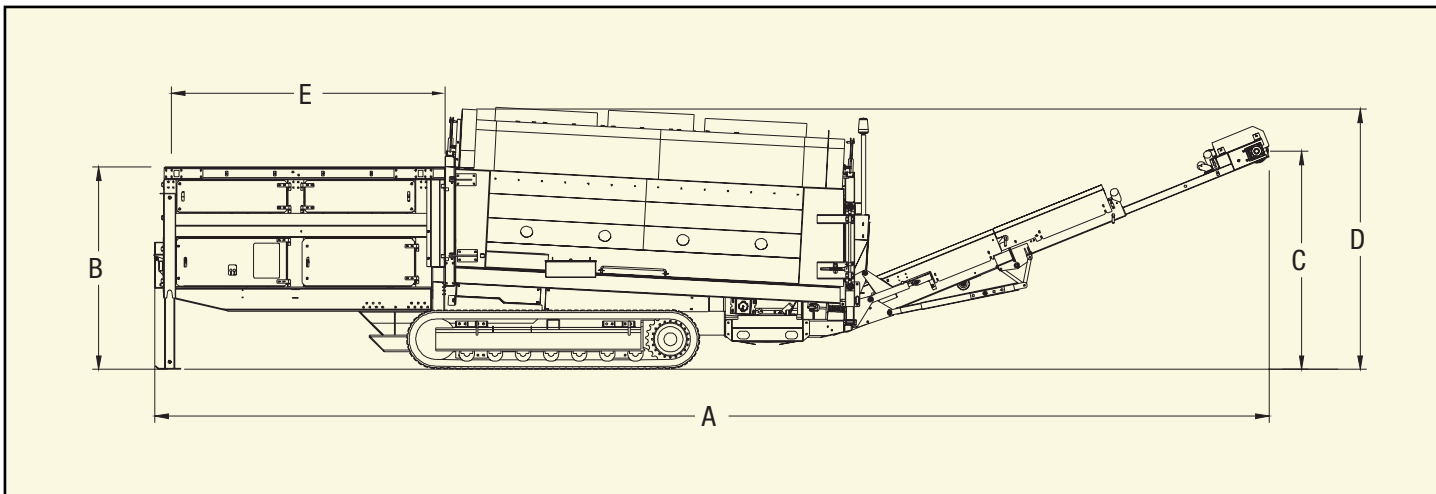

# 760

## 760 Tracked Working Dimensions

A	B	C	D	E
13879	2516	2718	3237	3409
45' 6"	8' 3"	8' 11"	10' 7"	11' 2"

## 760 Tracked Transport Dimensions

Length:	Width:	Height:
10.04m (32' 11")	2.62m (8' 7")	3.24m (10' 7")

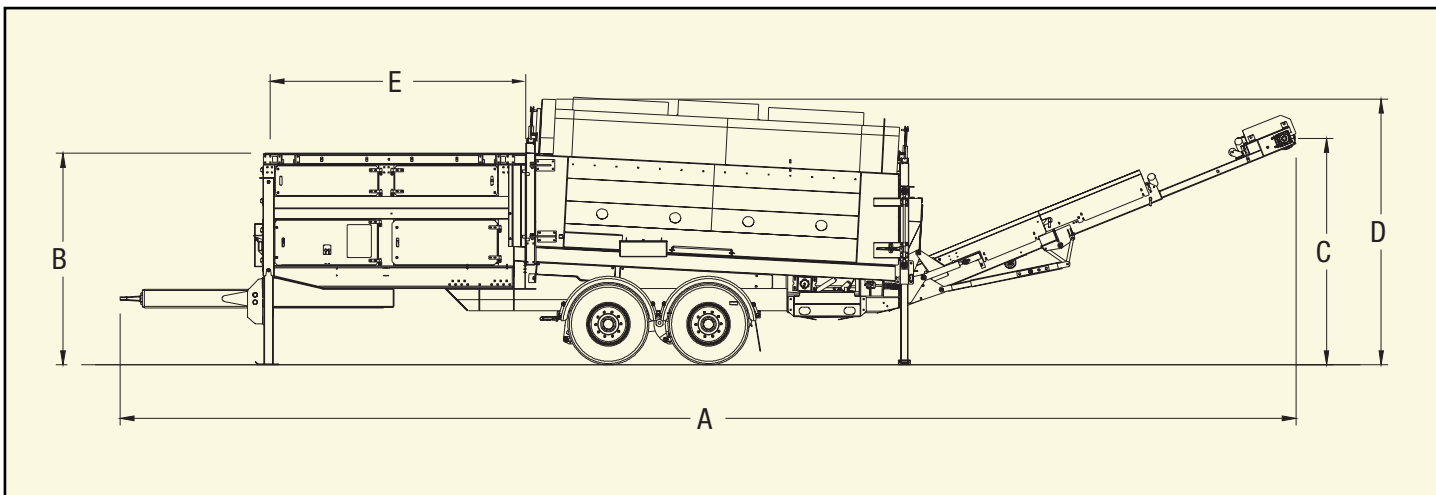

# 760

## 760 Wheeled Working Dimensions

A	B	C	D	E
15615	2809	3025	3530	3409
51' 3"	9' 3"	9' 11"	11' 7"	11' 2"

## 760 Wheeled Transport Dimensions

Length:	Width:	Height:
11.77m (38' 8")	2.5m (8' 2")	3.55m (11' 8")

**Omagh Office:**

Drumquin Road, Omagh, Co. Tyrone,  
N. Ireland, BT78 5PN.  
Tel: +44 (0) 28 82 418 700  
Fax: +44 (0) 28 82 244 294 (Sales)  
82 243 487 (Spares)  
82 252 740 (Technical)  
E-mail: [mail@finlayhydrascreens.com](mailto:mail@finlayhydrascreens.com)  
Web Site: [www.finlayhydrascreens.com](http://www.finlayhydrascreens.com)

**US Office:**

11001 Electron Drive,  
Louisville, KY 40299  
Tel: 001 502 736 5261  
Fax: 001 502 736 5205  
E-mail: [sales@finlay.us](mailto:sales@finlay.us)  
Web Site: [www.finlayhydrascreens.com](http://www.finlayhydrascreens.com)

All specifications subject to change without prior notification.  
Der Hersteller behält sich vor, alle Angaben ohne vorherige Mitteilung zu ändern.  
Toute spécifications susceptible d'être changée sans notice préalable.  
Todas las especificaciones estan sujetas a cambio sin previo aviso.  
Tutte le specifiche sono indicative e passibili di modifiche senza preavviso



**TEREX | FINLAY**

COMPLETE CRUSHING, SCREENING, WASHING & RECYCLING SOLUTIONS

